

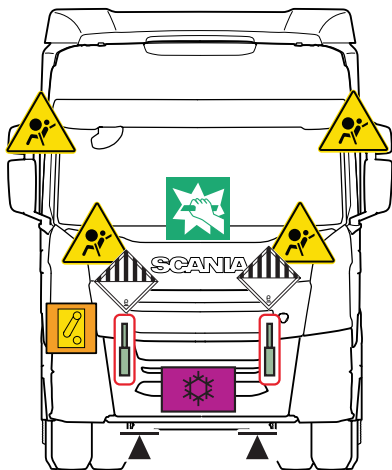

Scania 4x2 G BEV Electric

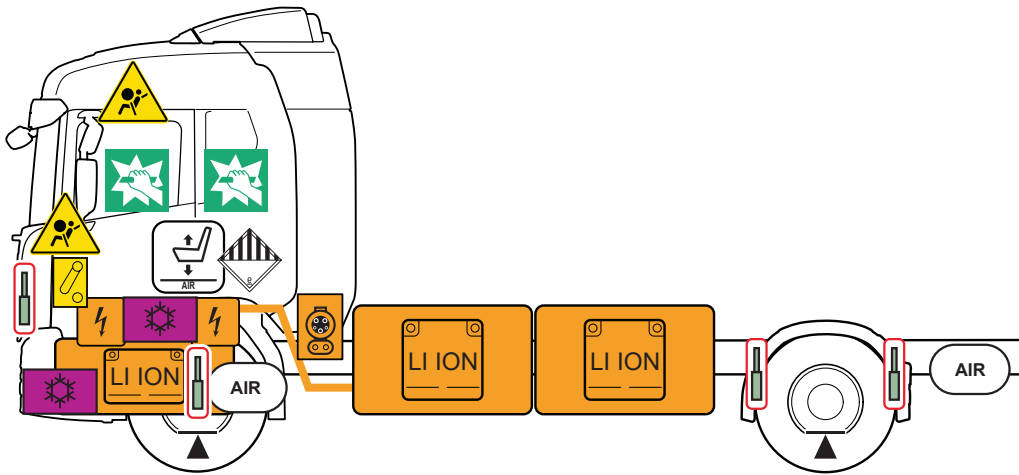
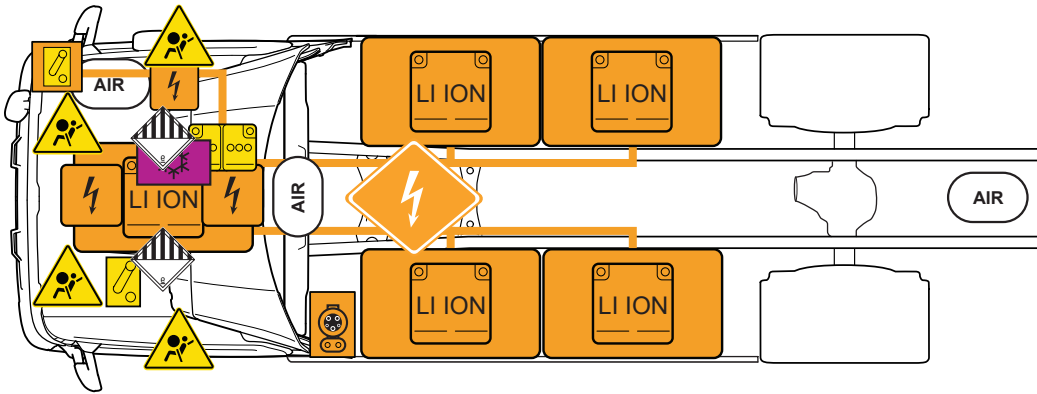
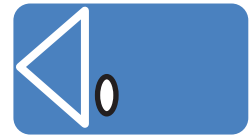

	Electric propulsion		High voltage component		Device to shut down VCA and VCB		Device to shut down VCB		Seat adjustment
	Lifting point		Low voltage battery, 24V		Traction voltage battery		Seat belt pretensioner		Fuel tank. diesel or biodiesel
	Airbag		Break to obtain access		Air tank		Triggered gas strut, triggered preloaded spring		Fire extinguisher
	Air-conditioning component		High voltage power cable/ component		CSS plug	Printed matter No. 00:01-133		Printed matter issue. 1	

# 1. Identifiers



# 2. Immobilisation / stabilisation / lifting

1. Activate the parking brake

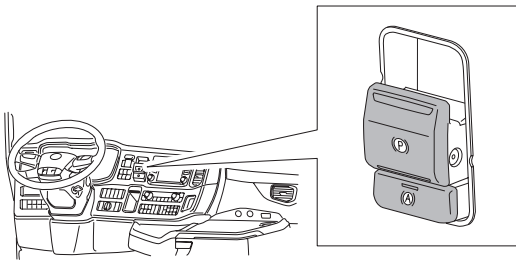

2. Lifting points

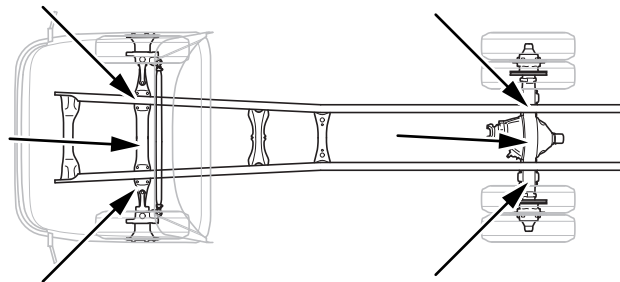

# 3. Disable direct hazards / safety regulations

The power switch for turning off all electric, power, VCA and VCB, in the vehicle is located in one of the below specified locations.

The switch (A) is located on the instrument panel. The battery switch (C) is located on the rear left panel.

The switch for turning of the propulsion battery, VCB, in the vehicle is located behind the front right panel (B).

**A.**



**B.**

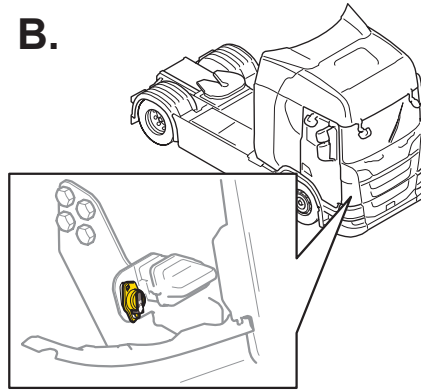

**C.**

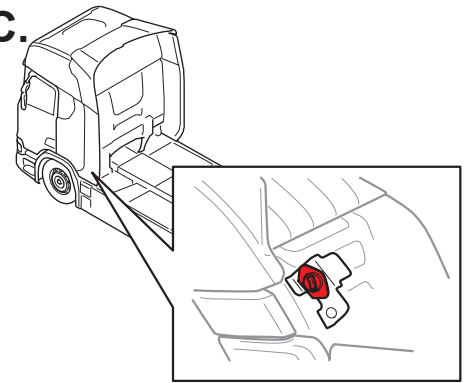

# 4. Access to the occupants

1. Through driver or passenger door.

2. Break through the side window.

*Note! Front windscreen is laminated.*

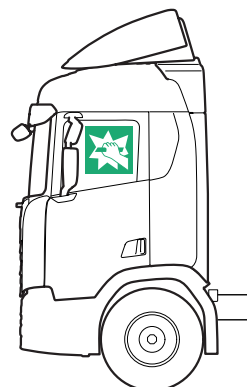
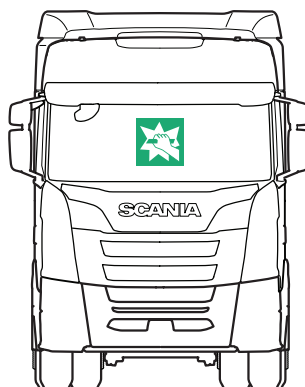

## 5. Stored energy / liquids / gases / solids

I. 650 V traction voltage lithium-ion battery.



II. Other liquids/gases



## 6. In case of fire

### I. Lithium-ion battery related fire Symptoms of the battery fire:

1. Fire alarm on a dashboard.
2. Smoke or streaks of intense fire rising from under the traction voltage cover.



Use large amount of water to put out the lithium-ion battery related fire.

*Note! Pay attention to overpressure valves (bursting membrane) (A).*

*Note! If electrolyte comes into contact with water, hydrofluoric acid and hydrogen gas may be formed.*



Do not use a class ABC fire extinguisher for the battery related fire! ABC Dry chemical is ineffective.



When fighting the fire with water, any electrical hazards have to be considered and rules have to be respected.



Hydrogen fluoride, carbon monoxide, carbon dioxide can be released. Wear Self Contained Breathing Apparatus (SCBA) and cover your skin.



Risk of battery re-ignition (see section 8. Towing/transportation/storage).

### II. Fire related to other material



Can only occur in the following compartments:



- auxiliary heater.
- electric machine.

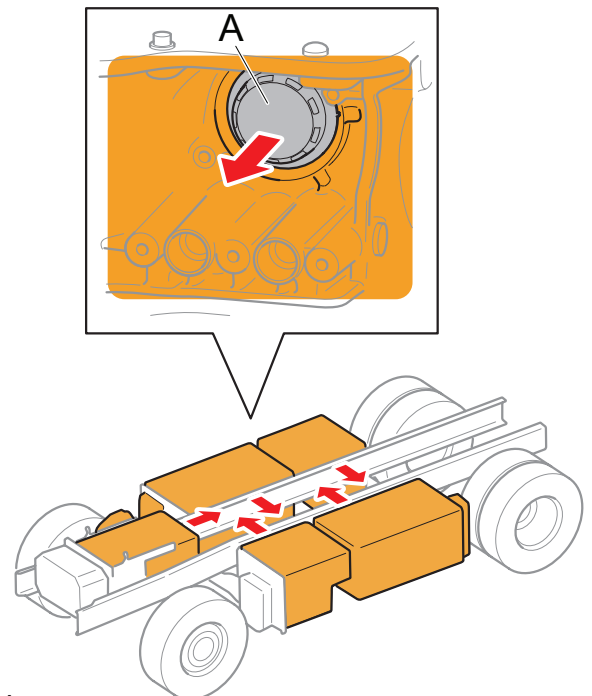

If other materials are involved, a class ABS fire extinguisher can be used.



## 7. In case of submersion

-  If possible:
1. Remove the vehicle from the water.
  2. Disable direct hazards (see section 3. Disable direct hazards / safety regulations).  
*Note! Risk of traction voltage battery fire after submerged in salt water.*
-  Risk of serious injury or death from electric shock.  
Wear appropriate Personal Protective Equipment (PPE).
- If electrolyte comes into contact with water, hydrofluoric acid and hydrogen gas may be formed.

## 8. Towing / transportation / storage

-  Store the vehicle at a safe distance from other vehicles, buildings and combustible objects.  
Risk of battery fire re-ignition after incident.  
Observe the batteries for at least 48 hours. Toxic and flammable gases may be released. In case of damaged/open battery cells, there is a risk for release of hydrofluoric acid and carbon monoxide.

1. The towing eye fastening point is located under the front bumper.



2. Shut down the power of the vehicle  
(See section 3. Disable direct hazards / safety regulations).
3. Keep away from inflammable and explosive materials.

Allowed methods:

1. Towing.  
(Note! Use only front towing eye for towing the vehicle with all wheels on the ground).
2. Lifting and towing
3. Transporting

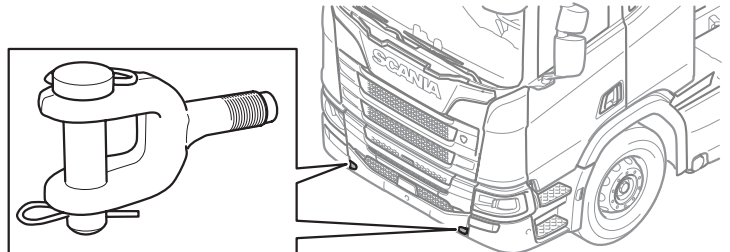

*Note!*  
*If the vehicle must be towed or transported more than 500 m, the speed must not exceed 10 km/h.*  
*Remove the drive shaft flange and the haft shaft from the drive axle.*  
*(See drivers manual for detailed information).*

## 9. Important additional information

- Do not touch or cut orange traction voltage power cables.
- Do not touch or open traction voltage components.
- Do not damage the battery pack, even if the propulsion system is deactivated.
- Do not step on or press on batteries.

## 10. Explanation of pictograms used

N/A