



Operator's manual

Scania 2.1

en-GB 2 775 269



Issue 2.0

Introduction	3
Responsibility	3
Display languages	3
System overview	4
Classified control system	4
Non-classified control system	5
Description of component parts	6
Main display	6
Auxiliary display	6
Network switch	6
Safety device unit	7
Gateway	7
Control panel	7
Fuel leakage monitor	8
Monitor for detecting water in fuel	8
Using the displays	9
Password	9
Buttons on the displays	9
Functions and display modes	9
Adjusting the brightness of the displays	12
Status bar	12
Starting the engine	15
Stopping the engine	15
Switch off the voltage	15
Alarms	15
Main menu	16
Ignition Off	16
Black Panel Mode	16
Settings	17
Backlight	18
Torque Limit	19
Fixed Speed	19
Adjust Fixed Speed	20
Single Speed	21
Emission level	21
Active Station	22
Log & Counters	23
Camera	23
Help	24
Alarm list	25
Typefaces and background colours	25
Filtering alarms	27
Turning off the buzzer during an alarm	27
Acknowledging 1 alarm	27
Acknowledging all alarms	27
Safety device unit	28
Buttons	28
LEDs	29
Engine shutdown at engine overspeed	30
Engine shutdown due to signal from sensor	31
Relays	31
Shutdown Coil	32

Introduction

This Operator's manual describes the operation of Scania instrumentation.

The information in this manual was correct at the time of going to press. Scania reserves the right to make alterations without prior notice.

Note:

Always use Scania spare parts for maintenance and repair.



REQUIREMENT!

Work on the low voltage circuit should only be carried out by qualified and experienced personnel.

Work on the high voltage circuit may only be carried out by an authorised electrician.

Responsibility

It is the responsibility of the installer to ensure that the installation of the electrical system is carried out in a professional manner. It is also the responsibility of the installer to ensure that the system is working satisfactorily and that all component parts meet legal requirements and regulations.

Display languages

In this Operator's manual the display interfaces are shown in English. It is however possible to set other languages.

System overview

Classified control system

The illustration shows an example of a control system that is prepared for classification.

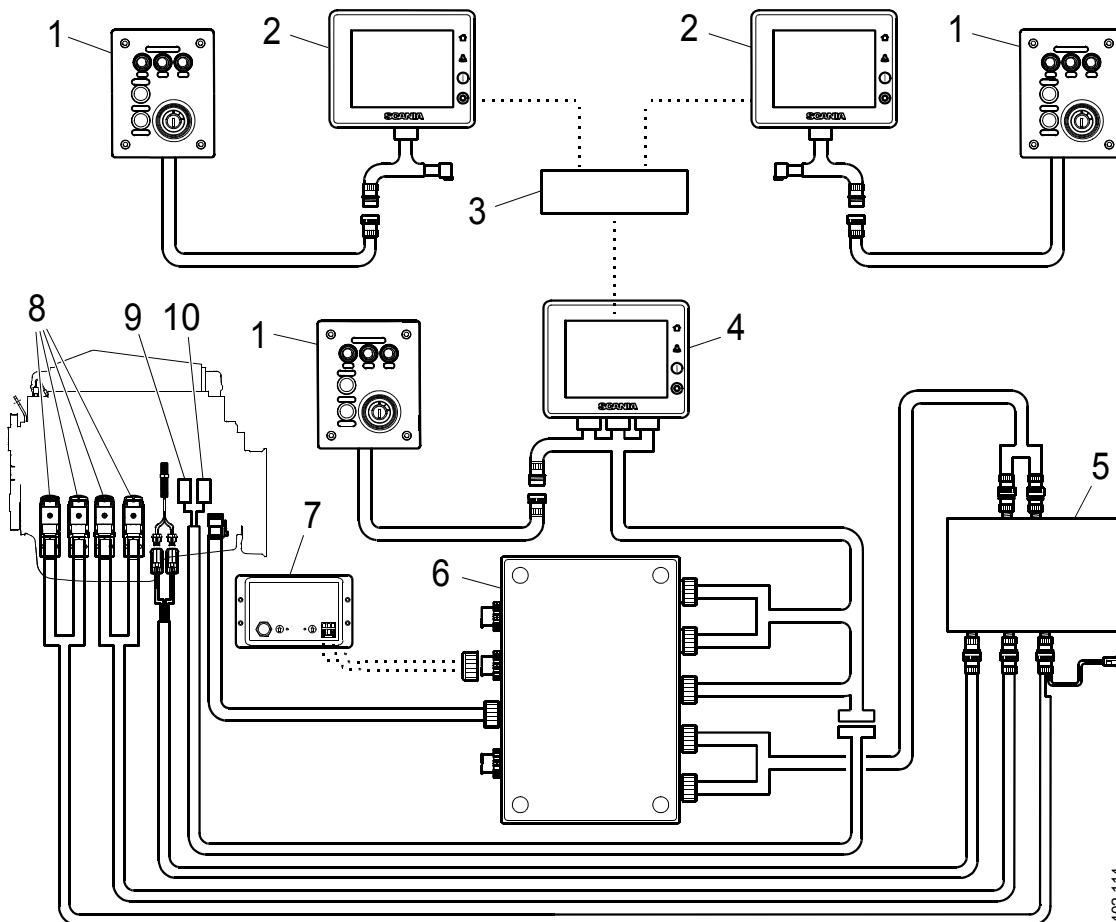

402 114

1. Control panel (option).
2. Auxiliary display (RP, option).
3. Network switch (option).
4. Main display (DCU).
5. Safety device unit (SDU).
6. Junction box.
7. Gateway (option).
8. Monitors on the engine required for classification.
9. Sensor for checking fuel leakage (classified engines with XPI).
10. Sensor for checking water in fuel (engines with XPI).

Non-classified control system.

The illustration shows an example of a control system which is not prepared for classification, i.e. a system without safety device units.

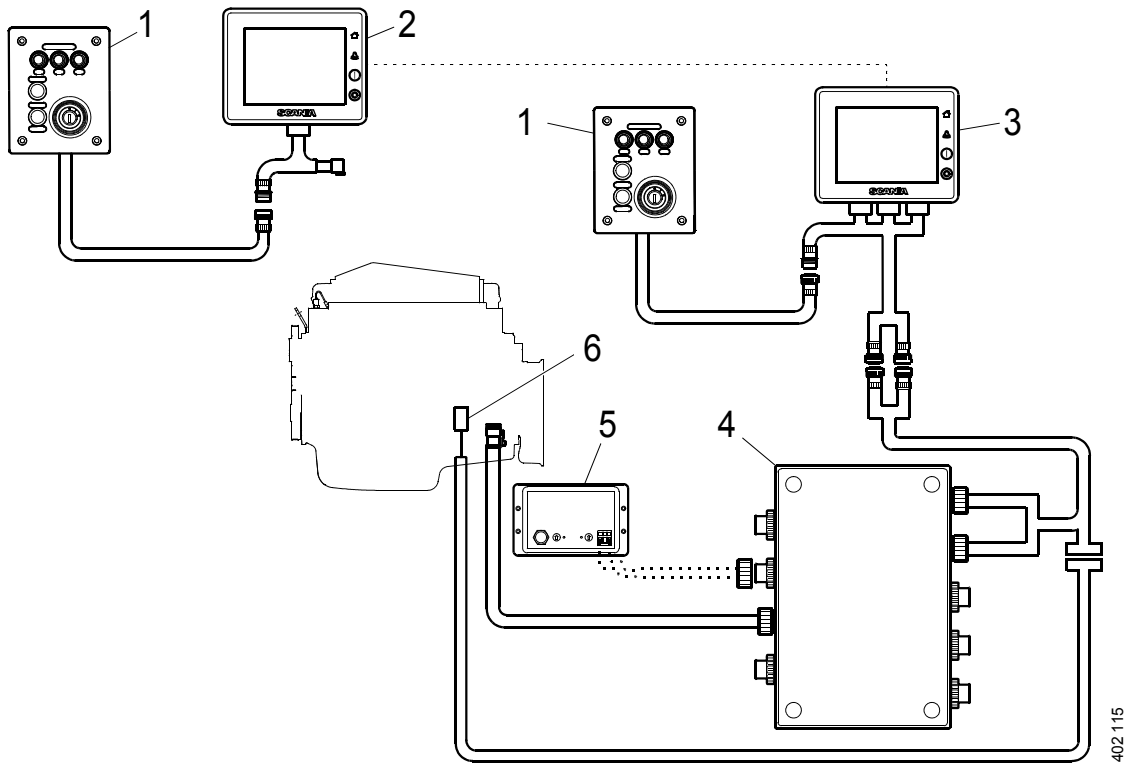

1. Control panel (option).
2. Auxiliary display (option).
3. Main display.
4. Junction box.
5. Gateway (option).
6. Sensor for checking water in fuel (engines with XPI).

Description of component parts

Main display

The main display is the main component in the control system. Values from the engine sensors are shown on the display. Commands and other user functions are also carried out on the main display.

Contact an authorised Scania workshop if the main display needs to be configured.

Auxiliary display

The auxiliary display, which is optional, shows the same things as the main display, with the same user interface.

The auxiliary display does not need configuring, as it loads the configuration from the main display which it is connected to. If the configuration of the main display has been changed, the auxiliary display adapts automatically to the new configuration. Therefore, it is easy to supplement the control system with an auxiliary display afterwards.

Network switch

A network switch is only required if more than 1 auxiliary display is connected to the control system. The displays can then be connected together via a network cable.

Scania recommends using a network switch, in order to make it simpler to expand the control system and connect a computer.

Safety device unit

The safety device unit is a requirement for classified control systems. The safety device unit has the same monitoring and shut-off functions as the main display.

Gateway

The gateway, which is an option, reads messages about position and speed via NMEA 2000, so that the control system can calculate fuel consumption per nautical mile.

Control panel

With the control panel, which is an option, the engine can be started and shut down. Using it, it is also possible to activate two engine speed settings.

Starter lock

The control panel starter lock (4) is used to start and stop the engine. The starter lock has the following positions:

- Position 0: The engine electrical system is switched off and the engine is stopped.
- Position 1: The engine electrical system is activated.
- Position 2: The starter motor is activated.

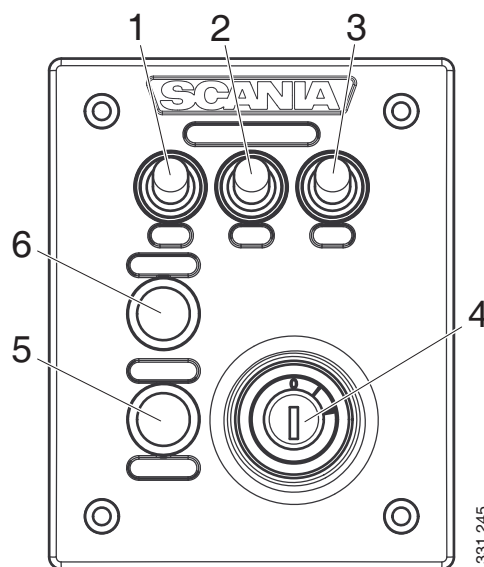

Control panel.

1. Control for activating engine speed setting 1.
2. Control for activating engine speed setting 2.
3. Control for activating engine speed setting 1 or 2.
4. Starter lock.
5. Not used.
6. Not used.

Fuel leakage monitor

On classified XPI engines, there is a monitor which detects fuel leakage from the high pressure pipes. If there is leakage, a warning comes on in the main display.

Monitor for detecting water in fuel

Engines with XPI use water-separating fuel filters. A monitor converts the water level in the filter to an electric signal which is sent to the main display.

Using the displays

The way the displays function depends on how the main display is configured. Configuration of the main display is not described in this Operator's manual. Contact an authorised Scania workshop if this needs to be carried out.

Password

If the control system does not have a control panel, a 4-digit password is used instead of a starter key. The password is provided by the installer.

Buttons on the displays

On the right-hand side of the displays, there are four buttons for direct access to the following features:

1. First instruments page and *Menu*
2. Alarm list
3. Starting the engine
4. Engine shutdown

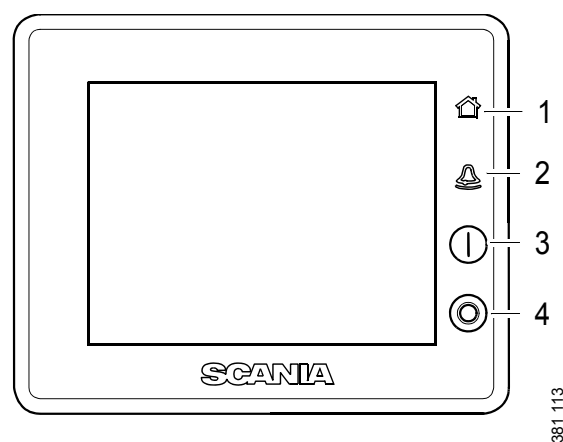

381 113

Functions and display modes

The displays are touch screens where you carry out every command by pressing directly on the display. Different touch areas on the display have different functions. For example, if you touch the left-hand side of the display on an instrument page, you get to the previous instrument page.

The displays have four different display modes:

- Instrument pages
- Alarm list
- *Select Page*
- *Menu*

Display buttons.

1. *Home button.*
2. *Alarm list.*
3. *Starting the engine.*
4. *Engine shutdown.*

Instrument pages

There are 4 preset instrument pages. If additional instrument pages have been configured, there may be more instrument pages.

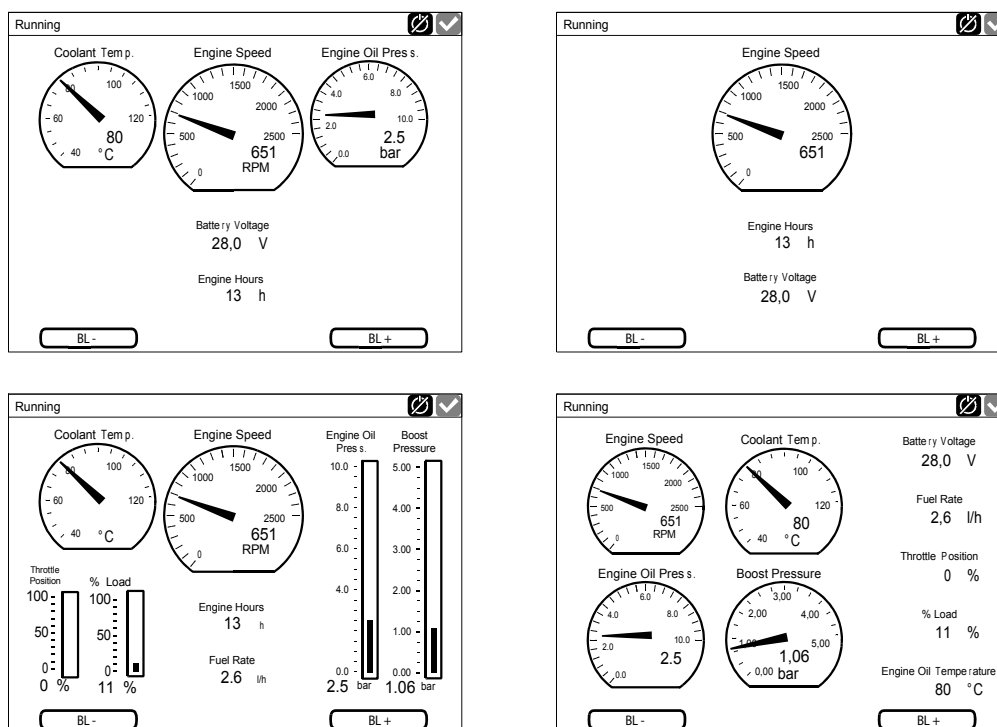

363 210

The 4 preset instrument pages.

To navigate between the instrument pages:

- You scroll between the instrument pages by pressing on the right- or left-hand side of the display. See illustration.
- You reach the first instrument page, by pressing the home key briefly. See illustration.
Note: A longer press on the home button (1 second) will open the main menu instead.

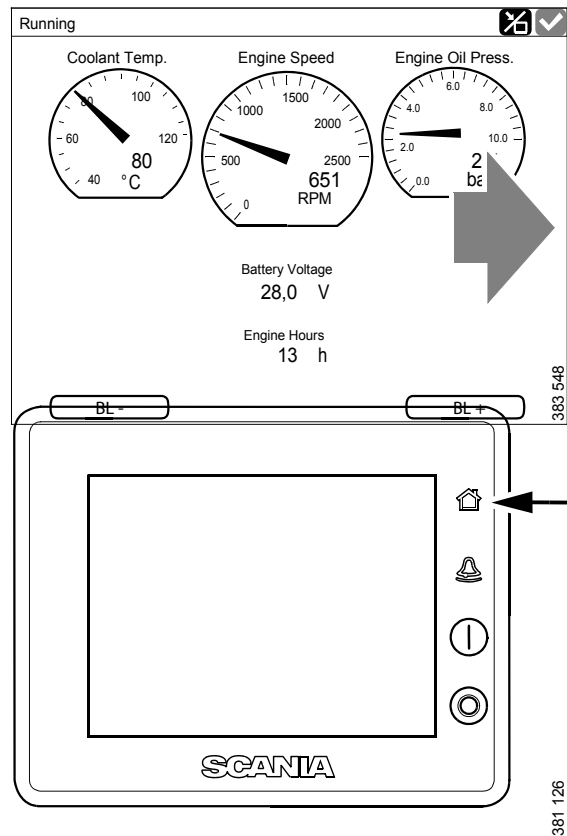

Select Page

You get to *Select Page* by pressing in the middle of the display when on one of the instrument pages.

In *Select Page* thumbnails of the instrument pages and the *Menu* are shown. Select the instrument page you wish to display by pressing the corresponding thumbnail, or select *Menu*.

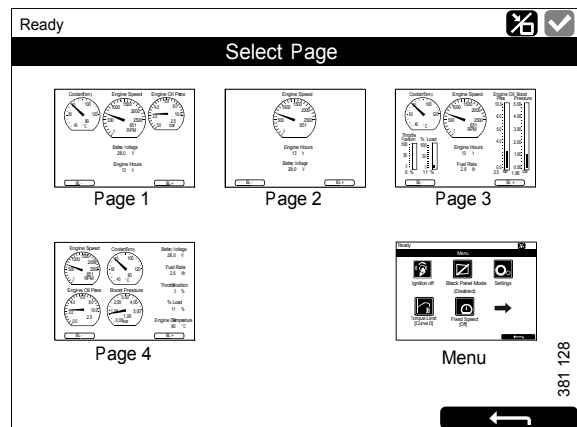

Adjusting the brightness of the displays

You can increase and decrease the brightness by pressing *BL-* and *BL+* on one of the instrument pages.

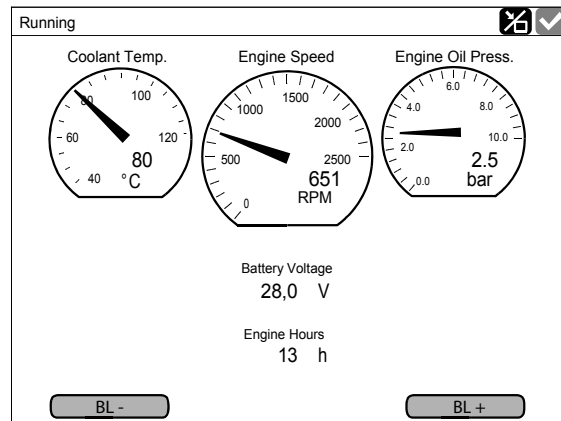

383 547

Decrease and increase the brightness of the displays.

Status bar

On the upper part of the displays there is a status bar. Engine status is displayed on the left-hand side of the status bar and the display status on the right-hand side.

Engine status

When the engine is started the status in the top left of the status bar changes from *Ready* to *Running*.

When the engine is switched of, the status changes from *Running* to *Ready*.

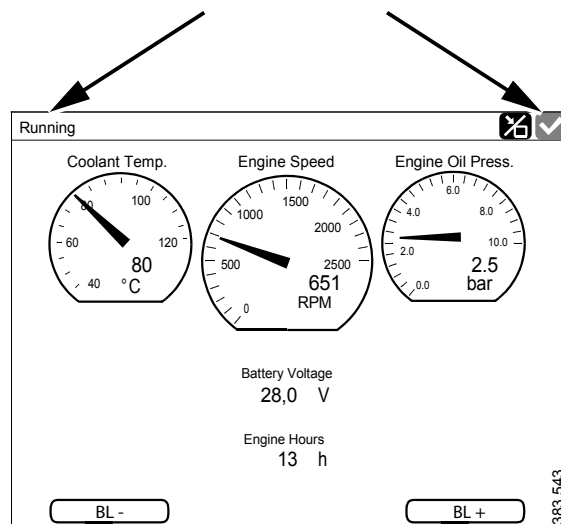











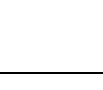

383 543

Status bar on an instrument page.

Display status symbols

The following display status symbols may be shown on the top right-hand side of the status bar:

Symbol	Meaning	Explanation
 347 940	Remote mode	The engine can be started and stopped from both the main display and an auxiliary display.
 347 941	Local mode	The engine can only be started and stopped from the main display.
 347 942	Override of engine shutdown	If this function is activated, an alarm is only given for events which normally lead to engine shutdown. The exception is engine overspeed, which is always activated.
 347 943	Everything OK	There are no alarms in the alarm list.
 402 022	IMO Tier II	The system is running at emission standard IMO Tier II.
 402 023	IMO Tier III	The system is running at emission standard IMO Tier III.
 402 021	Fault in exhaust gas after-treatment management system	The engine is not running at the selected emission standard. If the status bar lights up yellow and the icon is displayed, the problem is not critical but should be rectified as soon as possible. If the status bar lights up red and the icon is displayed, the fault is critical and must be rectified immediately.
 402 116	Low level of urea in the reductant tank	If the icon has a steady light, the level in the reductant tank is low. If the icon flashes every other second (1/2 Hz), the level in the reductant tank is very low. If the icon flashes twice per second (2 Hz), the reductant tank is empty.
 383 554	Gear engaged (unspecified)	Forward or reverse gear is engaged. The symbol is only displayed if the gear position function has been configured in the main display.
 383 553	Forward gear engaged	The symbol is only displayed if the gear position function has been configured in the main display.

Symbol	Meaning	Explanation
 383 552	Reverse engaged	The symbol is only displayed if the gear position function has been configured in the main display.
 383 551	Neutral gear	The symbol is only displayed if the gear position function has been configured in the main display.
 383 550	Active display	This symbol is only displayed in auxiliary displays, if present. It indicates that the auxiliary display is in charge and is controlling the engine.
 383 549	Maintenance due	If a maintenance interval has been configured, this symbol shows that maintenance is due.

Note:

Several symbols can be shown simultaneously.

Starting the engine

Hold the start button (1) in until the engine starts. When the engine has started the status in the top left of the status bar changes from *Ready* to *Running*.

Stopping the engine

Press and hold the engine shutdown button (2) until the engine shuts down. When the engine has stopped the status in the top left of the status bar changes from *Running* to *Ready*.

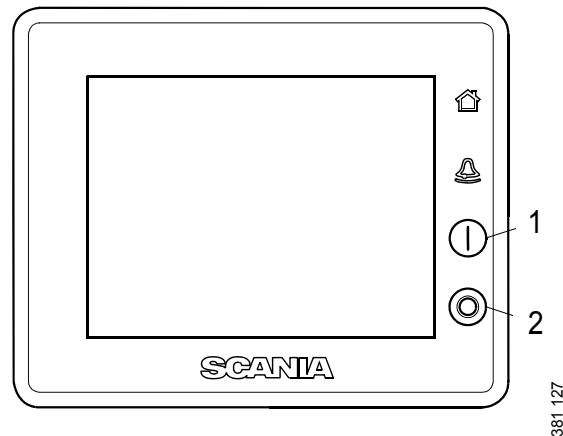

Switch off the voltage

Turn the key in the control panel. If the system does not have a control panel, press the *Ignition Off* button under *Menu*.

Note:

If there are multiple displays in the system and another display is in control, it can keep the system going.



Alarms

All alarms end up in the alarm list. Only important faults are displayed in the status bar.

Each time a new alarm is added to the alarm list, the following happens:

- The buzzer sounds.
- The status bar flashes either yellow or red.

The colour in the status bar has different meanings:

- Yellow means warning.
- Red means alarm or engine shutdown.

Note:

A red alarm always takes precedence over a yellow warning if both are generated simultaneously.

For further information on alarms, see the section [Alarm list](#).

Main menu

There are 2 different ways to get to the main menu (*Menu*):

- Press the home button for one second (see image).
Note: A brief press of the home button will take you to the first instrument page instead.
- Press in the middle of the display on one of the instrument pages and then select *Menu*.

When the *Menu* is opened the most recently used function is preselected. The functions in *Menu* are described in the following pages.

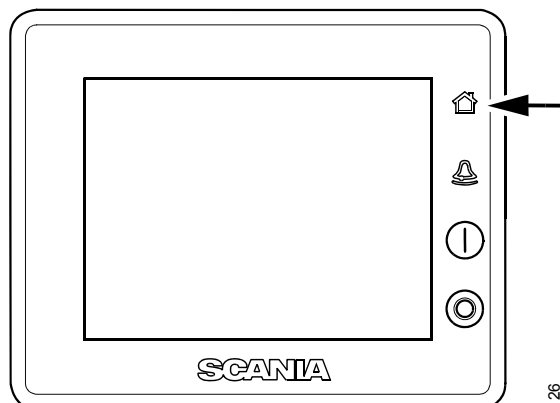

381 126

Ignition Off

Cuts the voltage.

Note:

The button is only displayed if the system does not have a control panel.



383 555

Black Panel Mode

The function is used to switch off the display to improve visibility in the dark.

Press the button to switch off the display completely. If you touch the display when the function is activated, the display comes on at the lowest brightness. It switches off automatically after a preset time. The standard setting is 5 seconds.

In the case of a serious faults, the display comes on even if *Black Panel Mode* is activated. However, with a less serious fault, only the buzzer sounds.

The function is deactivated by pressing the button again.

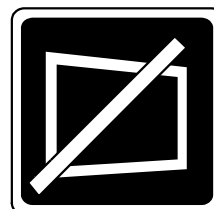







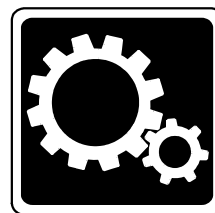

383 556



Settings

In *Menu > Settings* all display settings are made. In the main display, *Settings* consists of multiple pages. In any auxiliary displays, *Settings* consists of one page.



383 557

Setting	Symbol	Explanation
<i>Mode</i>	 347 940  347 941	<p>Select the main display operating mode. There are 2 modes to choose from:</p> <p><i>Remote</i> mode: The engine can be started and stopped from both the main display and an auxiliary display.</p> <p><i>Local</i> mode: The engine can only be started and stopped from the main display.</p> <p>Note: The button is only on the main display, not on any auxiliary displays.</p>
<i>Start Disabled</i>	 381 140	Select <i>Active</i> to deactivate engine start. Note: The button is only on the main display, not on any auxiliary displays.
<i>Shutdown Override</i>	 381 141	Select <i>Active</i> to activate engine shutdown override control. Then, events which normally lead to engine shutdown are signalled with an alarm only. However, engine overspeed is always enabled. Note: The button is only on the main display, not on any auxiliary displays.
<i>Prelube Override</i>	 381 142	The button is only on the main display, not on any auxiliary displays, and the function is not used.
<i>Button Beep</i>	 381 143	Select <i>Enabled</i> if you want a sound to be made every time you press the display. Select <i>Disabled</i> if no sound should be made when you press the display.
<i>Language</i>	 381 144	Select language. The languages which can be selected depend on how the display is configured.
<i>Units</i>	 381 146	Select unit of measurement: <i>Metric</i> or <i>U.S.</i>
<i>Wallpaper</i>	 381 147	Here you choose between different backgrounds for the instrument pages, for the <i>Menu</i> and for dialogue boxes.

Setting	Symbol	Explanation
<i>Engine Overspeed Test</i>	 381 148	Select <i>Active</i> to activate the engine overspeed test. When the engine overspeed test is activated, the limit value for engine overspeed is temporarily reduced to the nominal engine speed (engine speed is indicated on the engine data plate). Start the engine to carry out the test. The engine overspeed test is deactivated automatically after a timeout or when actual engine overspeed is detected in the test. Note: The button is only on the main display, not on any auxiliary displays.
<i>Connect a PC</i>	 381 149	This function is used when configuring the main display and updating software. Contact an authorised Scania workshop if any of this needs to be carried out. Note: The button is only on the main display, not on any auxiliary displays.
<i>Administration</i>	 381 150	In the administration section the display is configured, which can only be done by an authorised Scania workshop. It is therefore password-protected.

Backlight

Note:

The button is only on any additional display, not on the main displays.

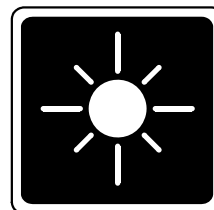

383 561

Here you can adjust the brightness of the auxiliary display. You can also adjust the brightness with *BL+* and *BL-* on the instrument pages.

Torque Limit

When you press *Torque Limit*, the *Torque Limit Selection* window opens.

Torque limitation is different types of power curves which the engine should follow. Power curves can only be configured by an approved Scania workshop.

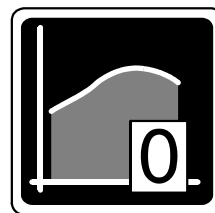

383 558

Setting	Description
<i>Curve 0</i>	Maximum engine torque.
<i>Curve 1</i>	Maximum engine torque, another lower engine torque requested.
<i>Curve 2</i>	Customer defined engine torque.
<i>Curve 3</i>	Customer defined engine torque.
<i>Input Controlled</i>	Activation of curve 1-3 via inputs on the main display, if this has been configured.

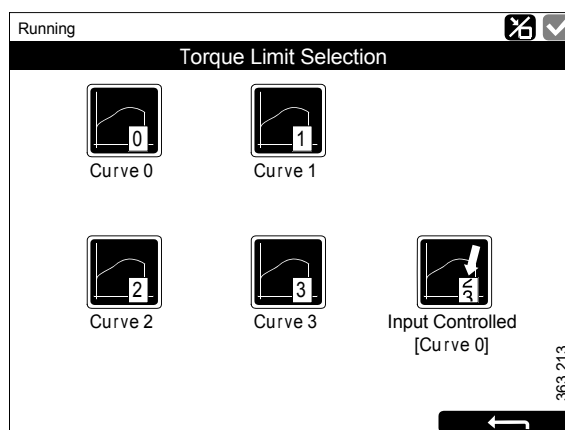

363 213

Note:

Customer defined engine torques are always lower than the maximum engine torque.

Fixed Speed

When you press *Fixed Speed*, the *Mode* window opens.

Here you activate and deactivate the engine speed setting. You can choose from the following options:

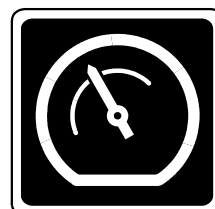

402 026

Setting	Description
<i>Fixed Speed Mode 1</i>	Activate engine speed setting 1.
<i>Fixed Speed Mode 2</i>	Activate engine speed setting 2.
<i>Fixed Speed Off</i>	Deactivate engine speed setting.

In order to activate engine speed setting 1 or 2, the engine must be running, the display in question must have control (active display) and the throttle must be at 0%.

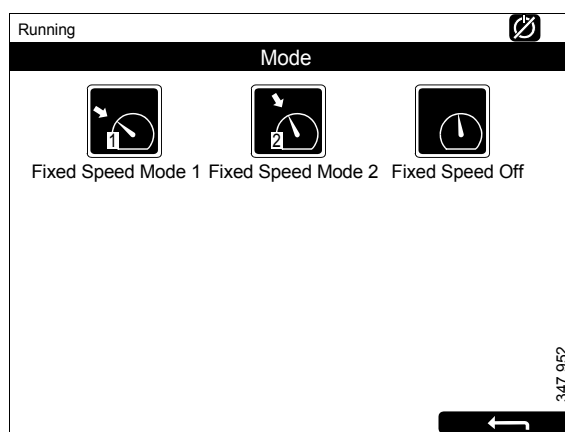

347 952

Adjust Fixed Speed

When you press *Adjust Fixed Speed*, the *Fixed Speed Adjustment* window opens. Here you adjust engine speed setting 1 and 2.

You can only adjust an engine speed setting if you have first activated it. This can be done in 2 different ways:

- Via *Menu* > *Fixed Speed* in the displays, see the previous section.
- Via the engine speed setting control on the control panel.

The following 2 engine speed settings are in *Adjust Fixed Speed*:

- *Fixed Speed Mode 1* is an engine speed which can be set between high and low idling. High and low idling vary depending on the type of engine.
- *Fixed Speed Mode 2* is an engine speed which can be set between 450 and 2,000 rpm.

Proceed as follows to adjust engine speed setting 1 or 2:

1. Select the engine speed setting to be adjusted.
2. Press the activate button, i.e. the arrow button underneath the minus button for 3 to 6 s to access the adjustment mode.
3. Step to the desired engine speed using the + and - buttons.
4. Save the desired engine speed by keeping the activate button depressed for 3 to 6 seconds. No confirmation is shown but the setting is saved.
5. Exit the menu by pressing the return arrow.

When either of the engine speed settings is activated, the engine speed goes up or down to the last saved engine speed setting.

A Scania workshop can set the torque limit for both engine speed settings. The engine speed settings are isochronous.

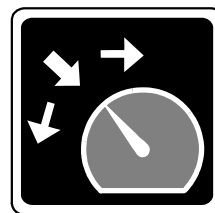

383 562

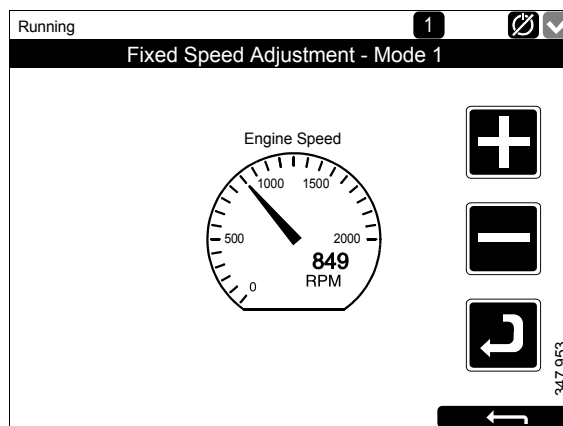

Single Speed

For engines configured as single-speed engines, the *Single Speed* function opens the *Mode* window.

In *Mode* you can select the engine speed setting. You can choose from the following options:

Setting	Description
Nominal	Nominal engine speed.
1 500 rpm	1,500 revolutions per minute.
1 800 rpm	1,800 revolutions per minute.
Low idling	Low idling.

In order to activate the engine speed settings, the engine must be running, the display in question must have control (active display) and the throttle must be at 0%.

To change between the settings, Low Idling must always be selected first, or the engine must be switched off.

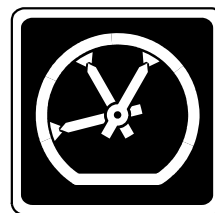

402 027

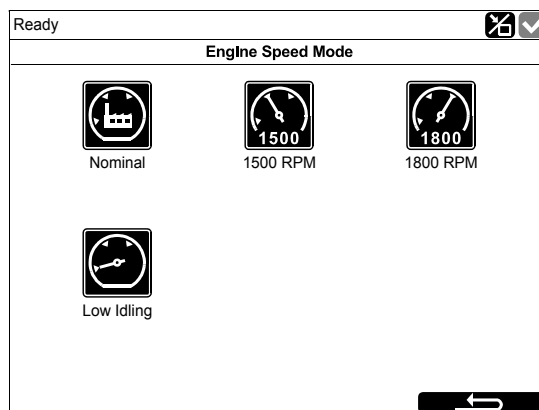

402 014

Emission level

Here you can choose to activate and deactivate IMO Tier II or IMO Tier III.

Note:

The button is only visible if an exhaust gas after-treatment management system is installed and operator checks are enabled.

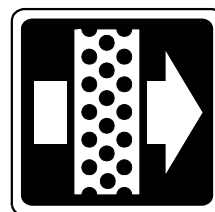

402 024

Active Station

Note:

The button is only on any additional display, not on the main displays.



383 560

Here, you activate and deactivate the option for the auxiliary display to have active display status, i.e. *Active Station*. This means that the auxiliary display controls the engine.

There may be several auxiliary displays in the system controlling the same engine, but only one auxiliary display can be active at any time.

Activating Active Station status

How to request that the auxiliary display become an active display:

- Select an engine and press *Request*.

A request is sent to the auxiliary display which currently has active display status.

If the engine icon has a yellow star in the status bar at the top of the window, as in the illustration, this means that the engine is currently being controlled by this auxiliary display.

Note:

If there is only one auxiliary display in the system, it still may not be the active display.

When you have activated *Active Station* once, the setting is saved, even when the auxiliary display is restarted.

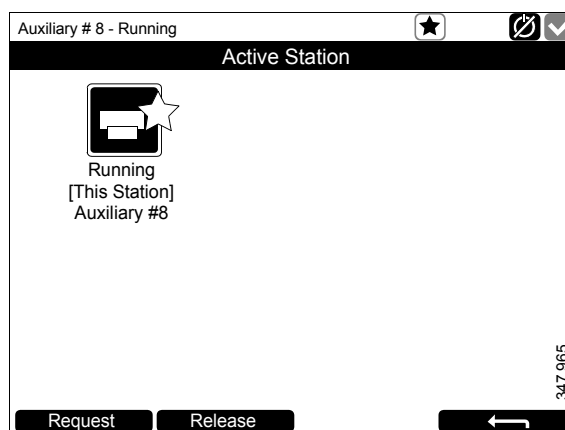

347 965

Deactivating Active Station status

If you deactivate the *Active Station* status for the auxiliary display, other auxiliary displays with lower priorities can control the engine. Proceed as follows:

- Select an engine and press *Release*.

Log & Counters

Here, a log of engine operating hours and all warnings and alerts is shown. When you have pressed *Log & Counters*, the following buttons are shown:



383 563

Counters

This submenu contains counters for

- the engine's total operating hours and fuel consumption (*Total*),
- operating hours and fuel consumption since start (*Since Start*),
- operating hours and fuel consumption since reset (*Since Reset*).

The values for *Since Start* are reset automatically each time the engine is started.

The values for *Since Reset* are reset by pressing *Reset* at the bottom left of the *Counters* window.

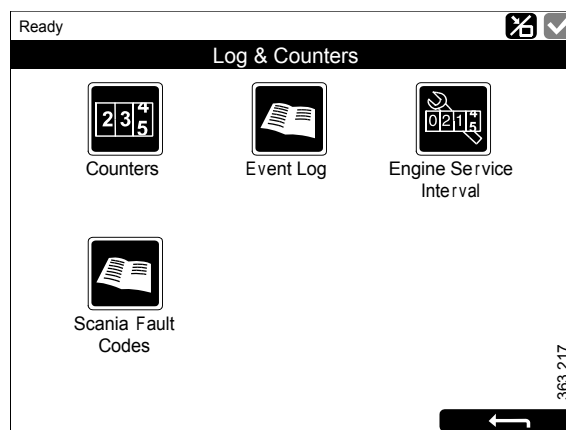

363 217

Event Log

All events (warnings and alarms) are saved in the display and can be shown in *Event Log*.

Press an event to see information on when it first occurred, when it was acknowledged (if it is possible to acknowledge the event) and when it disappeared.

Engine Service Interval

Not used.

Scania Fault Codes

This shows Scania fault codes in DTC format. These can make things easier when contacting a Scania workshop.

Camera

The *Camera* button is only on any additional display, but is not used.

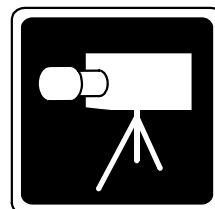

383 565

Help

In *Help* there are options for troubleshooting and for the software version and IP address of the displays. When you have pressed *Help*, the following buttons are shown:



383 564

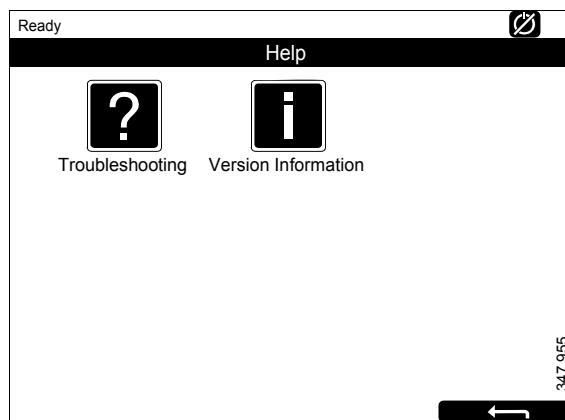

347 955

Troubleshooting

There are options here to troubleshoot the display. Select using the buttons within which area the troubleshooting should be carried out. Note that there are 3 pages of options in the main display.

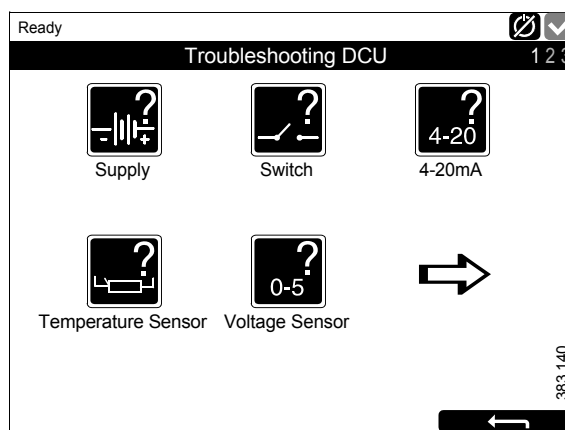

383 140

Version Information

Information about the display hardware version, software version and operating system are shown here. When connecting via CAN, the software version of the engine control unit is shown.

The display IP address is also shown here. The IP address is needed to connect the main display to a computer.

Configuration Overview

In *Configuration Overview*, which is only shown in auxiliary displays, the settings made for the auxiliary display are shown.

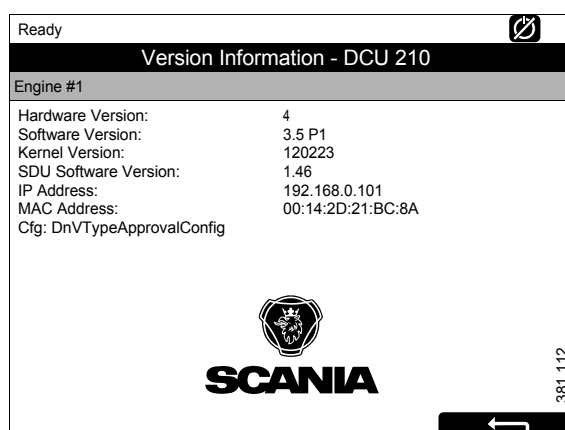

381 112

Alarm list

The alarm list is displayed and functions in the same way on the main display and any auxiliary displays. The alarm list displays alarms and engine shutdowns and warning and diagnostic messages.

You open the alarm list by pressing the button on the display (see illustration).

Typefaces and background colours

The following principles apply to how warnings and alarms are shown in the alarm list:

- An event which is not acknowledged is displayed using bold.
- An acknowledged event is displayed using normal text.
- An alarm and an engine shutdown are displayed using a red background. During engine shutdown, a stop signal is also displayed.
- A warning is displayed using a yellow background.
- A diagnosis message is displayed using a white background.
- An event which is not acknowledged and has turned inactive is displayed using a grey background.



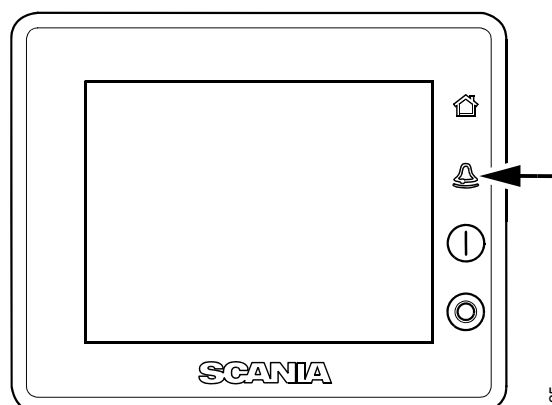

Example: The coolant temperature has exceeded the limit value and then returned to a normal level before the operator has had time to acknowledge the event.

This table lists examples of how different events are shown in the alarm list.



381 125

Alarm list	
Type of alarm	Display
New active alarm or engine shutdown.	Bold with red background.
Acknowledged active alarm or engine shutdown.	Red background.
Not acknowledged inactive alarm.	Red text with grey background.
New active warning.	Bold with yellow background.
Acknowledged active warning.	Yellow background.
Not acknowledged inactive warning.	Yellow text with grey background.
New active diagnostic message.	Bold with white background.
Acknowledged diagnostic message.	White background.
Not acknowledged inactive diagnostic message.	Black text with grey background.

Alarms for exhaust gas aftertreatment	
Symbol	Explanation
<div style="border: 1px solid black; padding: 5px;"> <p style="text-align: center;">SCR System Alert</p> <p>The bypass valve has to be manually opened! </p> </div> <p style="text-align: right; margin-right: 10px;">402 017</p>	<p>The symbol shows that the exhaust routing valve needs to be opened manually.</p> <p>Refer to the engine operator's manual for instructions on how to open and close the exhaust routing valve.</p>
<div style="border: 1px solid black; padding: 5px;"> <p style="text-align: center;">SCR System Alert</p> <p>Check aftertreatment system! Risk for overheated components. </p> </div> <p style="text-align: right; margin-right: 10px;">402 019</p>	<p>Part of the exhaust gas aftertreatment management system is overheated. Check the exhaust gas aftertreatment management system for anomalies.</p>
<div style="border: 1px solid black; padding: 5px;"> <p style="text-align: center;">SCR System Alert</p> <p>Aftertreatment system clogged! Check system. </p> </div> <p style="text-align: right; margin-right: 10px;">402 018</p>	<p>The exhaust gas aftertreatment management system is blocked. Check the system for anomalies.</p>
<div style="border: 1px solid black; padding: 5px;"> <p style="text-align: center;">SCR System Alert</p> <p>Mechanical bypass incorrectly set? Ensure that the bypass valve is closed. </p> </div> <p style="text-align: right; margin-right: 10px;">402 016</p>	<p>The exhaust routing valve is not in the position that the control unit has requested. Check the exhaust routing valve.</p>
<div style="border: 1px solid black; padding: 5px;"> <p style="text-align: center;">SCR System Alert</p> <p>After run in progress. Do not switch off the battery master switch. </p> </div> <p style="text-align: right; margin-right: 10px;">402 015</p>	<p>Post-running, do not switch off the main power switch. Components in the engine need to cool down. The system switches off when post-running is complete.</p>

Note:

For the message to disappear from the display, it must be acknowledged.

Filtering alarms

In the alarm list, the alarms can be filtered in 3 different groups:

- All alarms
- Display alarms
- Diagnostics

Main display

You activate the different filters by pressing the respective section at the bottom of the display. On line 2 in the alarm list, the filter which is active is displayed.

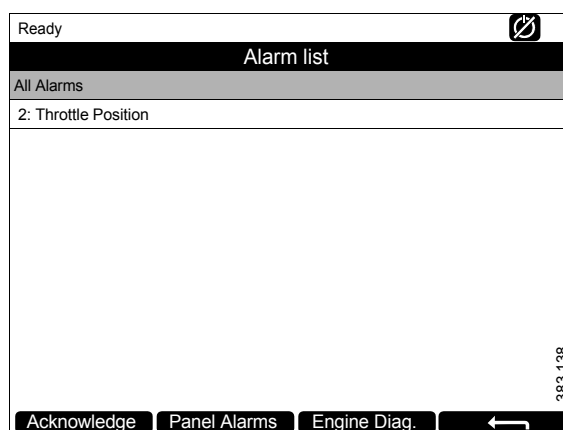

Alarm list in the main display.

Auxiliary display

Press *Alarm views*. In the dialog box, select the group you wish to be displayed.

If more than one engine is connected to the system, you can choose the engine you wish to see alarms for by pressing *Engine Views*.

Turning off the buzzer during an alarm

The buzzer is switched off when the alarm list is opened. If the buzzer begins to sound when the alarm list is open, you can switch it off by pressing *Acknowledge*.

Acknowledging 1 alarm

In the alarm list:

- Select the alarm to be acknowledged. If there is more information to display the row will be extended.
- Press *Acknowledge*.

Acknowledging all alarms

In the alarm list:

- Keep the *Acknowledge* button depressed for 1 second.

Note:

Active alarms will remain in the alarm list.

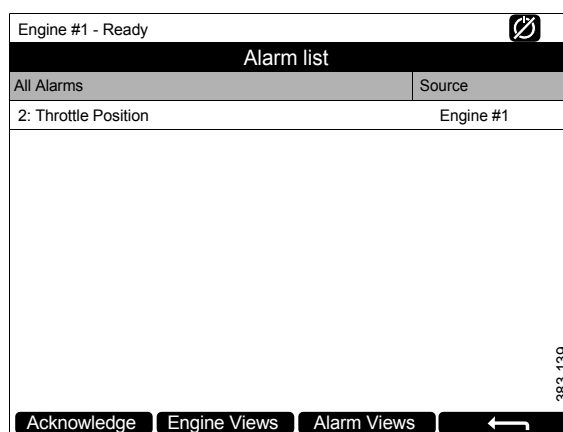

Alarm list in auxiliary display.

Alarms from safety device unit

If the alarm is generated via the safety device unit, it must be acknowledged in both the safety device unit and on the main display.

Safety device unit

The safety device unit has its own monitors and sensors. An alarm which has been generated via the safety device unit must also be acknowledged on the main display.

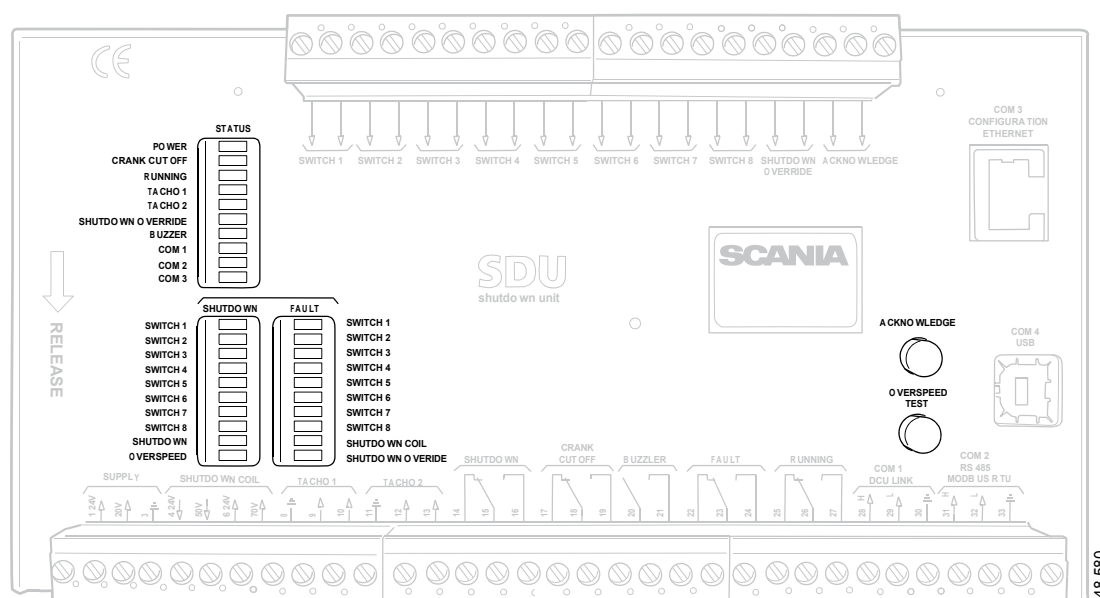

Safety device unit.

Buttons

Button	Description
<i>Acknowledge</i>	With the <i>Acknowledge</i> button all faults and engine shutdowns are acknowledged.
<i>Overspeed Test</i>	<p>How to carry out an overspeed test: When the engine is switched off, keep the <i>Overspeed Test</i> button depressed until the <i>Overspeed</i> LED starts flashing quickly. The safety device unit is now in test mode, and the limit value for engine overspeed is reduced to 95% of the set overspeed limit value. Then start the engine.</p> <p>The overspeed test can be deactivated in 3 different ways:</p> <ul style="list-style-type: none"> • The test is completed and is finished with an engine shutdown due to overspeed at 95% of the set overspeed limit value. • Press the <i>Overspeed Test</i> button. • Automatic deactivation after 5 minutes.

LEDs

The LEDs indicate status, engine shutdown or faults. When an LED is flashing, there is a new event which has not been acknowledged. When an LED is constantly on, there is an event which has been acknowledged but which is still active.

Status LEDs

LED	Description
<i>Power</i>	On when the safety device unit has a voltage above 21 V. Flashes if the voltage is below 21 V. Alarm if the voltage is below 21 V for more than 30 seconds. If the voltage drops below 18 V, the safety device unit shuts down all channels.
<i>Crank Cutoff</i>	Lights when the engine speed is above the set limit value.
<i>Running</i>	Lights when the safety device unit gets a signal that the engine speed is above the set limit value, which is normally 400 rpm.
<i>Tacho 1/Tacho 2</i>	Lights when the engine speed is above 5 rpm.
<i>Shutdown Override</i>	Lights when engine shutdown override control is activated.
<i>Buzzer</i>	Lights when the buzzer is activated.
<i>COM 1</i>	Flashes when the safety module communicates with the main display.
<i>COM 2</i>	Flashes when the safety module communicates via Modbus RTU interface.
<i>COM 3</i>	Flashes when the safety module communicates with the Ethernet interface.

LEDs for engine shutdown and faults

Shutdown

LED	Description
<i>Switch 1</i>	Lights at engine shutdown due to impermissible engine oil pressure.
<i>Switch 2</i>	Lights at engine shutdown due to high coolant temperature.
<i>Switch 3</i>	Lights at engine shutdown due to remote controlled emergency stop.
<i>Switch 4</i>	Lights at engine shutdown due to too high coolant pressure.
<i>Switch 5–8</i>	Lights at engine shutdown due to customer configured settings.
<i>Shutdown</i>	Lights at all engine shutdowns.
<i>Overspeed</i>	Lights at engine overspeed. Flashes rapidly at engine overspeed test.

Fault

LED	Description
<i>Switch 1–8</i>	Lights at open circuit for the respective sensor.
<i>Shutdown Coil</i>	Lights at open circuit for the <i>Shutdown Coil</i> output.
<i>Shutdown Override</i>	Lights at open circuit for the <i>Shutdown Override</i> input.

Engine shutdown at engine overspeed

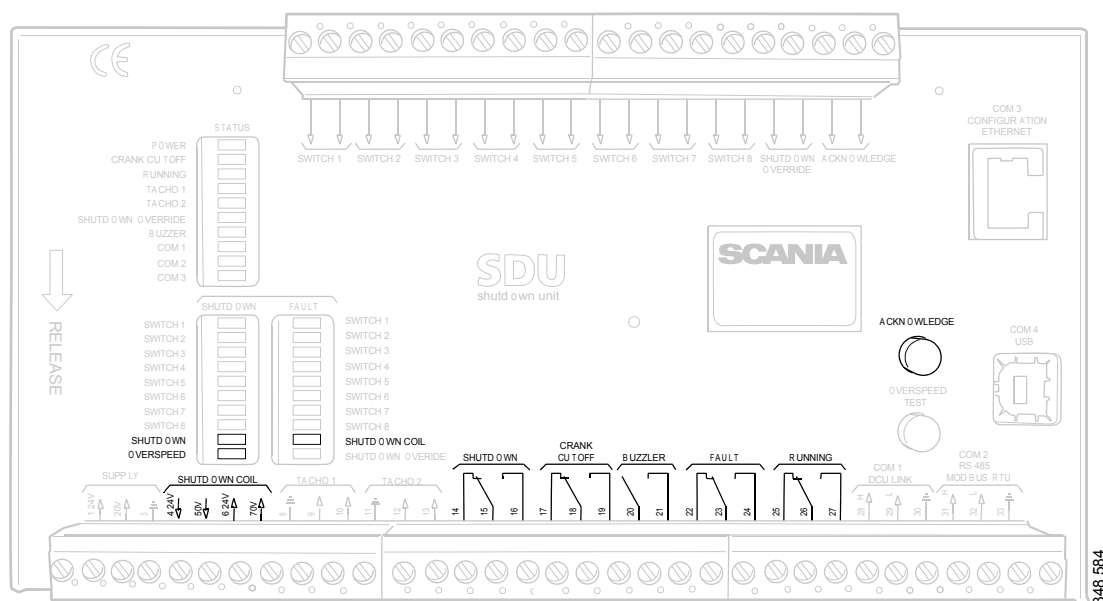

Safety device unit.

If a signal is sent to one of the 2 engine speed inputs that the engine speed exceeds the limit value, the safety device unit shuts off the engine.

Override of engine shutdown

It is not possible to override engine shutdown at engine overspeed. The engine is always shut off in case of engine overspeed.

Indication

The red *Overspeed* LED lights. The red *Shutdown* LED lights.

Acknowledgement

When engine shutdown has occurred: Acknowledge the engine shutdown with the *Acknowledge* button on the safety device unit.

Engine shutdown due to signal from sensor

If any of the sensors indicates engine shutdown the safety device unit activates engine shutdown.

Override of engine shutdown

All sensor channels can be configured to disregard the engine shutdown override signal.

Indication

The red *Switch* LED for the corresponding sensor lights. The red *Shutdown* LED lights.

Acknowledgement

When engine shutdown has occurred: Acknowledge the engine shutdown with the *Acknowledge* button on the safety device unit.

Relays

Relay	Description
<i>Shutdown</i>	Is activated at all engine shutdowns. Active until the engine has been stopped and the operator has acknowledged the event.
<i>Crank Cutoff</i>	Is activated at a set engine speed, which is normally 400 rpm. Is deactivated when the safety device unit has obtained a signal that the engine has stopped.
<i>Buzzer</i>	Is activated for all new engine shutdowns and faults. Is deactivated when the operator has acknowledged the event.
<i>Fault</i>	Fault indicator, i.e. is activated for all new faults. Is deactivated when the fault has been acknowledged and has disappeared.
<i>Running</i>	Is activated at a set engine speed, which is normally 400 rpm. Is deactivated when the safety device unit has obtained a signal that the engine has stopped.

Shutdown Coil

The *Shutdown Coil* output is activated at all engine shutdowns. The output is deactivated 8 seconds after the engine has stopped.

Detecting an open circuit

If there is an open circuit in the electrical cables connected to junction block 4 and 5, the red *Shutdown Coil* LED lights. The impedance should be in the region of 300-700 ohms.

Electric power supply

Shutdown Coil is supplied with power separately via junction block 6 and 7.